

TIBOR SIGNATURE SERIES



CLEANING

After each use, back off the drag completely and rinse the reel thoroughly with fresh, warm water giving special attention to the backing and the perforations in the Spool. (Do not let the reel soak). The reel should be shaken to remove excess water and left in an open area (indoors) to dry overnight. The following day, put the reel through all of its drag settings and then return to free spool for storage. Periodically, especially after extensive exposure to saltwater, the line and backing should be removed and wiped down with a wet cloth to remove salt.

When the reel, line and backing are completely dry, the reel should be stored in its protective pouch.

MAINTENANCE

All reels are lubricated at the factory prior to assembly and relubrication is generally not necessary. Should you wish to disassemble your reel for cleaning and/or relubrication, insert a penny into the Drag Adjustment Stop Nut; unscrew and remove the Nut. Unscrew the Drag Adjustment Knob and remove. Turn the Spool backwards (against the drag) until it moves freely. Remove the Spool. (Do not unscrew the Signature End Cap). Clean as necessary and reassemble. If you wish to lubricate the Cork Drag Disc, use only a small amount of Tibor Graphite Lube.

Please note: Monofilament line is not recommended for use on Tibor reels. Should you have any questions about line for your reel, please contact your authorized Tibor dealer.

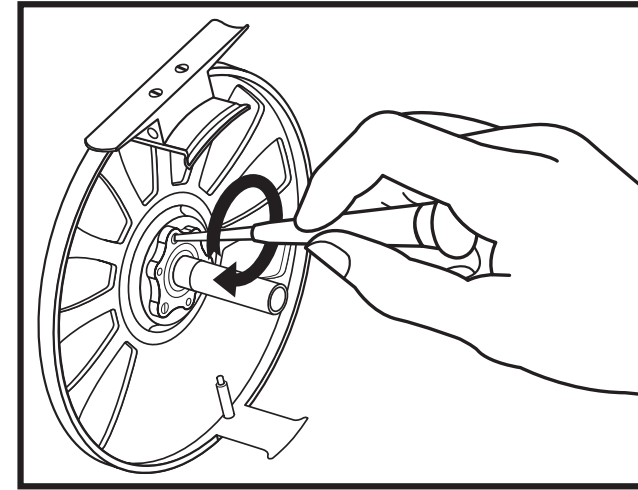

CONVERSION FROM RIGHT TO LEFT HAND RETRIEVE

Tibor Signature reels are shipped from the factory with right hand retrieve unless specified. An authorized dealer can easily convert any Tibor reel from right to left hand retrieve for you. You may also convert the reel yourself by reversing the Clutch Dogs. Please refer to the numbered parts list on the reverse side:

1. Insert a penny into the Drag Adjustment Stop Nut (Part #1), unscrew and remove the Nut. Unscrew the Drag Knob (Part #2) and remove.
2. Separate the Spool from the Frame.
3. Locate the three Clutch Pins (Part #13) at the base of the Main Shaft (Part #15). Depress and rotate the Clutch Pins 180° from the factory setting for left hand retrieve.
4. Mate Spool and Frame. Replace Drag Knob and tighten all the way down. Replace Stop Nut and tighten with a penny.

TIBOR REELS
The World's Finest Fly Reels

TIBOR SIGNATURE SERIES

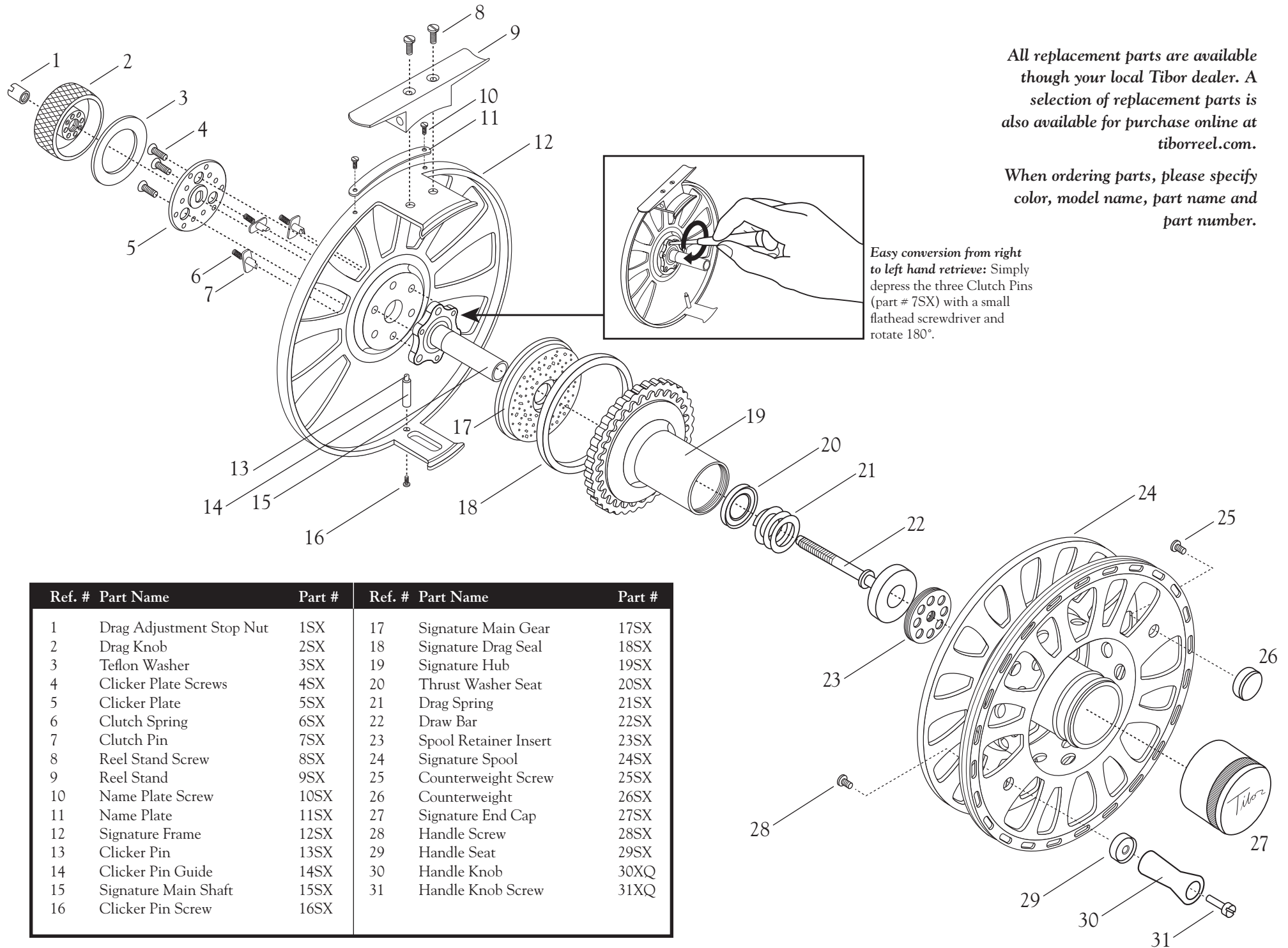

All replacement parts are available though your local Tibor dealer. A selection of replacement parts is also available for purchase online at tiborreel.com.

When ordering parts, please specify color, model name, part name and part number.

Easy conversion from right to left hand retrieve: Simply depress the three Clutch Pins (part # 7SX) with a small flathead screwdriver and rotate 180°.

Ref. #	Part Name	Part #	Ref. #	Part Name	Part #
1	Drag Adjustment Stop Nut	1SX	17	Signature Main Gear	17SX
2	Drag Knob	2SX	18	Signature Drag Seal	18SX
3	Teflon Washer	3SX	19	Signature Hub	19SX
4	Clicker Plate Screws	4SX	20	Thrust Washer Seat	20SX
5	Clicker Plate	5SX	21	Drag Spring	21SX
6	Clutch Spring	6SX	22	Draw Bar	22SX
7	Clutch Pin	7SX	23	Spool Retainer Insert	23SX
8	Reel Stand Screw	8SX	24	Signature Spool	24SX
9	Reel Stand	9SX	25	Counterweight Screw	25SX
10	Name Plate Screw	10SX	26	Counterweight	26SX
11	Name Plate	11SX	27	Signature End Cap	27SX
12	Signature Frame	12SX	28	Handle Screw	28SX
13	Clicker Pin	13SX	29	Handle Seat	29SX
14	Clicker Pin Guide	14SX	30	Handle Knob	30XQ
15	Signature Main Shaft	15SX	31	Handle Knob Screw	31XQ
16	Clicker Pin Screw	16SX			