

Tibor Fly Reels



MAINTENANCE

After each use, back off the drag completely and rinse the reel thoroughly with fresh, warm water giving special attention to the backing and the perforations in the Spool. (Do not let the reel soak). Shake the reel to remove excess water and leave in an open area (indoors) to dry overnight. The following day, put the reel through all of its drag settings and then return to free spool for storage. Periodically, especially after extensive exposure to saltwater, the line and backing should be removed and wiped down with a wet cloth to remove salt. When the reel, line and backing are completely dry, the reel should be stored in its protective pouch.

All reels are lubricated at the factory prior to assembly and re-lubrication is generally not necessary. **Should you wish to disassemble your reel for cleaning, the only tool you will need is a penny.** Insert the penny into the Drag Adjustment Stop Nut; unscrew and remove the Nut. Unscrew the Drag Adjustment Knob and remove. The Frame and Spool will now separate. Clean as necessary and reassemble, making sure not to disturb any grease on back of Spool. Be sure to tighten the Drag Knob

completely before replacing the Drag Adjustment Stop Nut. If you wish to lubricate the Cork Drag Disc, use only a small amount of Tibor Graphite Lube.

Please note: Exceeding the recommended capacity by over-filling the Spool and/or putting line on too tightly or with too much tension may damage the Spool and is not covered under warranty. Please refer to the capacity sizes on our website tiborreel.com and use the Backing Groove on the Spool as your guide. Monofilament backing is not recommended for use on Tibor reels. Should you have any questions about backing for your reel, please contact your authorized Tibor dealer.

CONVERSION FROM RIGHT TO LEFT HAND RETRIEVE

Tibor reels are shipped from the factory with right hand retrieve unless specified. An authorized dealer can easily convert any Tibor reel from right to left hand retrieve for you. You may also convert the reel yourself by reversing the Clutch Dogs. *Please refer to the numbered parts list on the reverse side.*

1. Begin by removing the Spool (part #14) from the Frame with a penny; the Main Gear (part #10) is held in place by a Snap Ring (part #31).
2. Unscrew the Clutch Screws (part #6).
3. Remove the Clutch Dogs (part #5); make sure the Bushing is retained between the Clutch Screw and the Clutch Dog.
4. Using tweezers, remove the Clutch Springs (part #9) and replace them in the opposite Retainer Blocks (part #7).
5. Replace the Clutch Dogs so they press against the Clutch Springs.
6. Tighten the Clutch Screws. Do not over-tighten, as this may strip the threads in the frame.
7. Reassemble the Spool and Frame.
8. Replace the Drag Knob (part #24) and tighten completely, before replacing the Drag Adjustment Stop Nut (part #23).



Tibor Fly Reels

All replacement parts are available through your local Tibor dealer. A selection of replacement parts is also available for purchase online at tiborreel.com.

When ordering parts, please specify model name (The Everglades, The Gulfstream, The Pacific) in addition to the complete part name and part number.

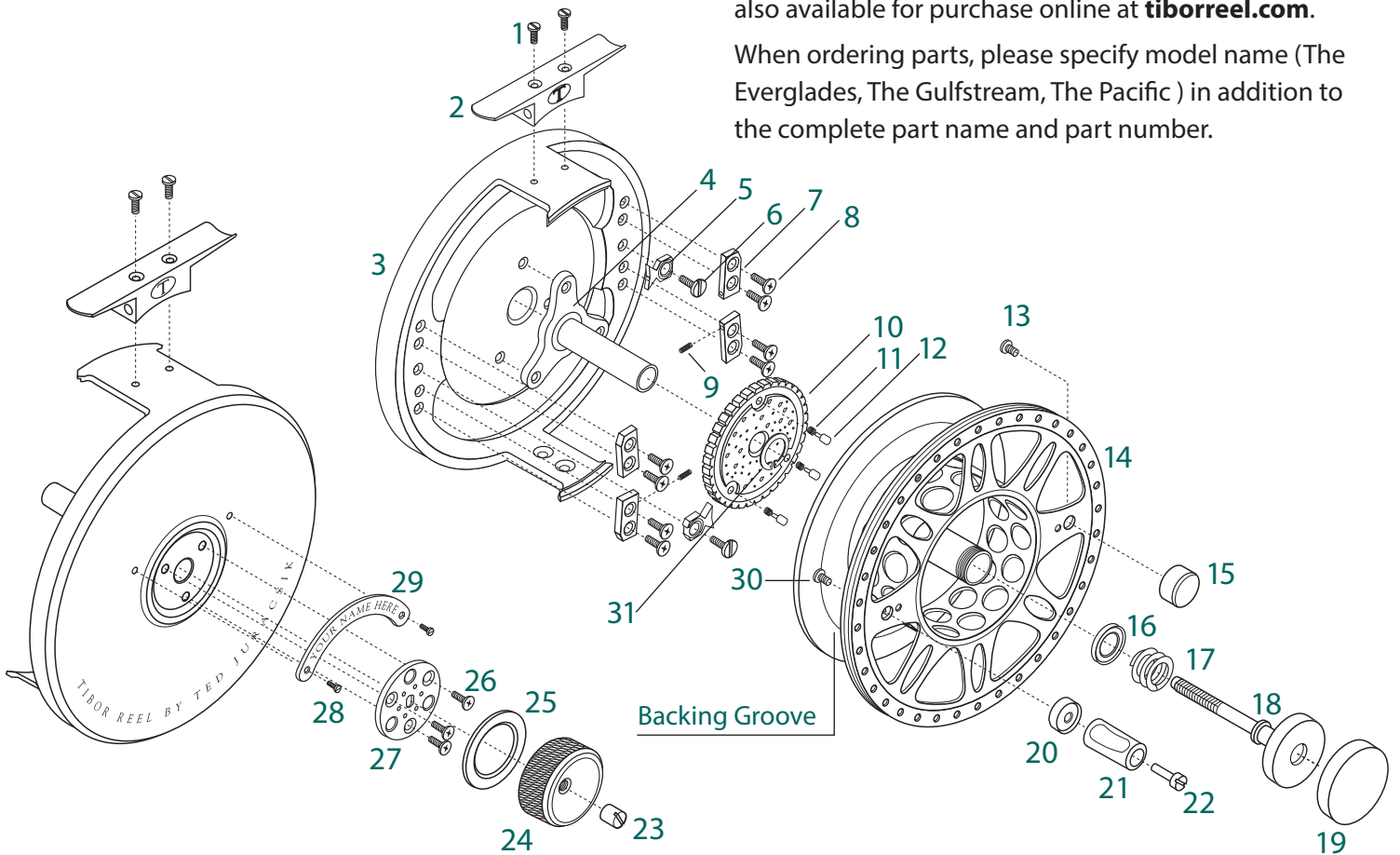

Ref.#	Part Name	Part#	Ref.#	Part Name	Part#
1	Reel Stand Screw	2X	17	Main Shaft Spring	19X
2	Reel Stand	4X	18	Draw Bar	20X
3	Frame	5X	19	End Cap	21X
4	Main Shaft	6X	20	Handle Knob Seat	22X
5	Clutch Dog	7X	21	Handle Knob	23X
6	Clutch Screw	8X	22	Handle Knob Screw	24X
7	Spring Retainer Block	9X	23	Drag Adjustment Stop Nut	25X
8	Spring Retainer Screw	10X	24	Drag Knob	26X
9	Clutch Spring	11X	25	Teflon Washer	27X
10	Main Gear	12X	26	Clicker Plate Screw	28X
11	Clicker Spring	13X	27	Clicker Plate	29X
12	Clicker Pin	14X	28	Name Plate Screw	30X
13	Counter Weight Screw	15X	29	Name Plate	31X
14	Spool	16X	30	Handle Screw	32X
15	Counter Weight	17X	31	Snap Ring	44X
16	Thrust Washer	18X			

