

# Billy Pate Anti-Reverse Fly Reels



## MAINTENANCE

All reels are lubricated at the factory prior to assembly and relubrication is generally not necessary. After each fishing trip, back off the Drag Adjustment Knob to release any pressure on the Drag Washer. Simply rinse off the reel with fresh water and shake dry. Do not soak reel. Allow reel to dry completely and store in protective pouch.

## SERVICE TOOL INFORMATION

A Service Tool is included with all new Billy Pate Reels. This Tool facilitates spool changes or further takedowns.

*Features of the service tool include:*

- A Wrench for the Star Nut over the Handle.
- A properly sized Screwdriver Blade to prevent screw head damage.

## DISASSEMBLY/REASSEMBLY:

*Please refer to the numbered parts list on the reverse side.*

1. Remove Handle Nut Screw (Part #26).
2. Remove Handle Nut (Part #25) using the Wrench provided. For left hand reels, remove by turning clockwise; for right hand reels, remove by turning counter-clockwise.
3. Back off the Drag Knob (part # 19). This will push the

Handle Arm (Part #22) off of the Main Gear. For left hand reels, remove the Drag Knob by turning clockwise. For right hand reels, remove the Drag Knob by turning counter-clockwise. **Note:** the Handle Washer (Part #23) is under the Handle Arm, between the Drag Knob and the Handle Arm.

4. Remove the Drag Washers (Part #'s 16, 17 & 18) and the Drag Spring (Part #15). **Note the order and position the Spring and Washers are in. They must be put back in the same order.**
5. Remove the Spool. Check the Cork Drag Surface and lubricate if needed with Tibor Graphite Lube.
6. Reassembly is the reverse of disassembly. Put the Spool back on the reel, making sure it sits in the Frame properly.
7. Put the Drag Spring (Part #15) back on the Main Gear.
8. Put the Drag Washer (Part #16) on the Main Gear, smoothest side up.
9. Put the Teflon Washer (Part #17) on the Main Gear (this part should have a little lube on it).
10. Put the Keyed Drag Washer (Part #18) on the Main Gear. The tab slips into the keyway on the gear, with "bumps" facing up.
11. Put the Drag Knob (Part #19) on, lube the bottom side where the dimples ride against the Keyed Washer and tighten down almost all the way.
12. Put the Handle Washer (Part #23) on with the smooth side down towards the Drag Knob.
13. Put the Handle Arm (Part #22) on. This part may fit a little snug.
14. Put the Handle Nut (Part #25) on. For left hand reels, turn counter-clockwise, for right hand reels, turn clockwise. Tighten down with the Wrench provided until snug, then line up the notch in the Handle Nut with the hole for the Handle Nut Screw (Part #26). If the Handle Arm is not tight enough, tighten to the next notch in the Handle Nut. **Use caution:** if the Handle Nut is tightened too much, it can bind the reel.
15. Put the Handle Nut Screw (Part #26) on and back the drag off.



# Billy Pate Anti-Reverse Fly Reels

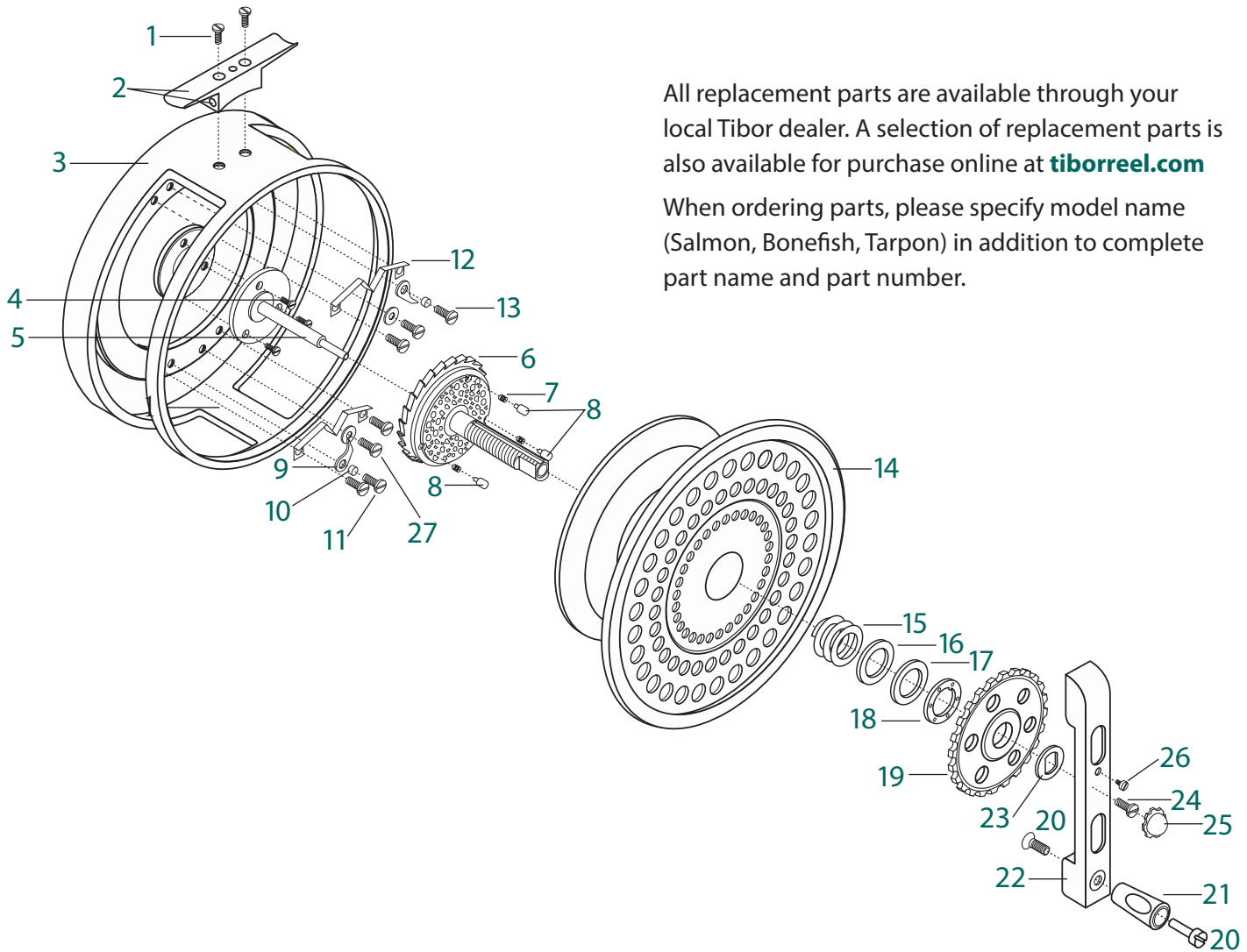

All replacement parts are available through your local Tibor dealer. A selection of replacement parts is also available for purchase online at [tiberreel.com](http://tiberreel.com)

When ordering parts, please specify model name (Salmon, Bonefish, Tarpon) in addition to complete part name and part number.

Ref.#	Part Name	Part#	Ref.#	Part Name	Part#
1	Reel Stand Screw	TCP-002	16	Drag Washer	BP-016
2	Reel Stand/Hook Keeper	XX-002	17	Teflon Drag Washer	BP-017
3	Frame	XX-003-XX	18	Keyed Drag Washer	BP-018
4	Main Shaft Screw	PCP-004	19	Drag Knob (right hand)	XX-019-RH-AR
5	Main Shaft	XX-005-AR		Drag Knob (left hand)	XX-019-LH-AR
6	Main Gear (right hand)	XX-006-RH-AR	20	Handle Knob Screw Assembly*	TCP-032/TB-024
	Main Gear (left hand)	XX-006-LH-AR	21	Handle Knob	BP-021-XX
7	Clicker Spring	BP-007-XX	22	Handle Arm	XX-022-AR
8	Clicker Pin	BP-008-XX	23	Handle Washer	BP-023-AR
9	Anti-Reverse Dog	BP-009	24	Main Shaft Screw	BP-024
10	Anti-Reverse Dog Bushing	BP-010	25	Handle Nut (right hand)	BP-025-RH-AR
11	Anti-Reverse Dog Screw	PCP-011		Handle Nut (left hand)	BP-025-LH-AR
12	Anti-Reverse Spring	BP-012	26	Handle Nut Screw	PCP-026-AR
13	Anti-Reverse Spring Screw	PCP-013	27	Anti-Reverse Dog Stop Screw*	PCP-013 Assembly
14	Spool	XX-014		Not Shown: Service Tool	BP-29
15	Drag Spring	XX-015			

\*These are multiple-part components.

